

RSM72 Remote - Start - Modules

Control Systems - Genset Controls - Timers/Monitors/Trips - Battery Chargers - Custom Products

These versatile controllers, set in compact 72mmsq DIN sized cases, can provide fully automatic start-up, monitoring and shutdown of Petrol, Diesel or Gas powered engines.

The front panel has up to seven 'High Intensity' LED's indicating system status. A rotary switch (where provided) can select up to four operational modes - see overleaf for more details.



RSM72C

OFF / RESET	Isolates Term.11 & Term.17 from Batt.+Ve. Used to manually stop the engine and reset all alarms. This is not an Isolator --- See page-3.
LAMP TEST	(RSM72B-- & RSM72C-- only) Off-Lamp Test-Auto-Man. Lights all LED's and provides a lamp test output (note: AUTO mode active).
AUTO	Switches battery positive to Terminal 17, ready to automatically start the engine (note: Starter inhibited during Pre-Heat Time) when Term.17 & Term.18 (Start + I/P) are externally connected via 'volt-free' contacts . The engine stops immediately this connection is broken.
MANUAL	Starts the engine immediately (subject to the Pre-Heat Timer), effectively linking Term.17 & 18 internally (see overleaf for option 'N').
TEST	(RSM72G-- only) Off-Auto-Man-Test. Provides an 'active-low' output when the engine has achieved 'crank-cut' speed and no fault shutdown is present. Designed to switch an external relay via 'fuel solenoid' +Ve (term.5). Its relay contacts would normally be used to break the 'mains-failure' sensing at the ATM72 (or other 'Auto-Transfer' circuit) to provide 'test on load'.

Dedicated inputs are provided for Cooling Fault (HET) and Low Oil Pressure (LOP) sensors which are disabled at run up until the Hold-Off timer has elapsed to allow the parameters to stabilise. These inputs can be individually configured to sense fault conditions that either close to, or open from -Ve.

The Auxiliary input (AUX) can be used as a spare channel if it is not required for use with Expansion Module(s). This channel operates immediately, activated by its input being switched to -Ve.

Operation In 'Auto' Mode

The RSM72 consumes negligible power until the 'Remote Start' Terminals 17 & 18 are connected, where upon the Pre-Heat output will activate and the Fuel relay energise. A short time later (after the Pre-Heat timer has elapsed) the Starter Relay will energise (subject to the 'Safety Circuit' -- see below) and the Pulse Timer starts the Crank cycle. As soon as the engine reaches 'Crank-Cut' speed (typically 40% of rated speed but adjustable from 15 to 60%) the Starter relay de-energises and is locked out. If the Crank Cycle times out first, the fuel relay is de-energised for an equal Dwell period (to allow the starter motor to cool down and the battery to partially recover). The Crank and Dwell cycles are now repeated until the engine starts or the system shuts down on 'Fail to Start' (at the end of the third Crank cycle, unless requested).

Safety Circuit - - The starter relay can only energise (for each Crank Cycle) if 'Low Oil Pressure' is sensed, to confirm that the engine is stationary. This is designed to prevent damage to the Starter & Ring Gear in the event of the unit not sensing that the engine has started (i.e. an open-circuit in the case of 'Alternator Sensing' or short-circuit in the case of 'Magnetic Pickup sensing'). **If the engine cannot be fitted with an 'Low Oil Pressure' switch - refer to page 5 of this document.**

Assuming that the engine has 'run up to speed', the starter relay will have de-energised and the Hold-Off timer (T0) activated. The tachometer circuitry continually monitors for Overspeed. When the hold-off timer has elapsed, the LOP and HET fault circuits are enabled. In the event of a shutdown, the fault Led is lit, the Alarm output is activated, Fuel (and Starter) relays are locked out and the LOP & HET channels disabled (first-up interlock).

ORDERING INFORMATION

Model No.	Mode Switch	Mode Control	LED-1 (Red)	LED-2 (Green)
RSM72A	Knob	Off - Auto - Man	DC on	Running
RSM72B	Knob	Off - Lamp Test - Auto - Man	DC on	Running
RSM72C	Knob	Off - Lamp Test - Auto - Man	DC on	Auto-Mode
RSM72F	(External)	(none)	DC on	Running
* RSM72G	Knob	Off - Auto - Man - Test	DC on	Running
RSM72K	Key	Man - Off - Auto	DC on	Auto-Mode
Options	Features			Term.
RSM72 - M	Magnetic Pick-Up (MPU) speed sensing in place of 'Main Alternator' frequency sensing.			9 & 10
RSM72 - - N	External stop/start push button control (via an external relay) in 'Manual' mode only.			
RSM72 - - - R	'Active-Low' drivers for external lamps &/or relays via a separate 8-way (top) connector.			a ---- h
RSM72 - - - - S	'Symbols' on front panel in place of text.			
* RSM72 - - - - - T	'Active-Low' driver output at the end of T0 period (& no fault shutdown)			7
RSM72 - - - - - V	Pre-Heat terminated after T0 time (max. 25sec from crank-cut) to suit certain engines			
* RSM72 - - - - - W	'Active-Low' driver output with engine running (& no fault shutdown)			7
RSM72 - - - - - X	LED-1 to show 'Aux.' channel 'Status' in place of 'DC on'. Please specify 'overstick' label!			
Input Phasing				
RSM72 - - -	Het (Cooling Fault) & Lop (Low Oil Pressure) are both 'closed to ground' (Batt -Ve) on fault			
RSM72 - - - / HR	'Het Reversed' - open from ground (Batt -Ve) on fault			
RSM72 - - - / LR	'Lop Reversed' - open from ground (Batt -Ve) on fault			
RSM72 - - - / HLR	'Het & Lop Reversed' - {both of the above} - open from ground (Batt -Ve) on fault			

NOTE: 1/ * These Models & Options are 'Mutually Exclusive' as they all use terminal 7, but for different functions!
 2/ 'Engine Running' is defined as 'crank-cut' lockout having activated (typically at 40% normal speed).
 3/ 'Active-Low' driver output(s) are open collector transistors, each capable of switching 40V / 300mA (non-inductive)
 4/ If you require spare or replacement units with 'Model Numbers' & / or 'Build Options' not listed here --- please contact our sales desk for the latest price and delivery. If possible, please quote the serial No. of the original unit.

SPECIAL BUILDS

RSM72 - - - / - - / X0? These 'X' numbers, indicate non-standard product, which has been manufactured to suit a specific customer. They do not appear in any catalogues and may only be available to the original customer. When re-ordering, please quote the full part number together with the 'Serial Number' of the original unit(s).

CUSTOMISED PRODUCTS

If you have a specific requirement that is not listed above; please contact our Sales Desk for a quotation. We can normally customise a standard product within a matter of days in order to provide a prototype (if not, production) unit.

CONNECTIONS

Always ensure that the correct wire sizes are used and that all terminals are tightened correctly.

Terminal	Description	Input / Output	Connect To -----
1 LOP	Low Oil Pressure	-Ve Input	Low Oil Pressure switch
2 HET	High Engine Temp.	-Ve Input	High Engine Temp. switch
3 Starter	Max. Load 16 Amps (resistive) *	+Ve Output	Solenoid or Solenoid Relay
4 Batt+	Supply +Ve		Battery positive
5 Fuel	Max. Load 16 Amps (resistive) *	+Ve Output	Solenoid or Solenoid Relay
6 Batt -	Common DC -Ve supply		Battery negative
7 (See text)			
8 C.F.	Charge Failure	+Ve Output	Charging Alternator (WL)
9 AC or MPU -	Speed sensing		115/230VAC (Main Alternator or
10 AC or MPU+			Magnetic Pick-Up (see 'Options')
11 Manual	'Manual' mode **	+Ve Output	External circuitry -- if required
12 Meter +	Analogue Meter Output	+Ve Output	RPM Meter / DC Voltmeter --- see text
13 Pre-Heat	Open Collector Transistor ***	-Ve Output	Pre-Heat control relay
14 Alarm	Open Collector Transistor ***	-Ve Output	Alarm control relay
15 Swt +Ve	Switched +Ve Output	+Ve Output	To power, 'Alarm' relay etc.
16 Aux	Auxiliary Shutdown	-Ve Input	Expansion Module(s) or Spare I/P
17 Auto	'Auto' Mode **	+Ve Output	Link to 18 via external 'volt-free'
18 Start	Autostart operation	+Ve Input	contacts for Remote Start operation
19 L.T.	Lamp Test	+Ve Input	'Global' Lamp Test circuits

NOTE : * De-rate to 14% for Inductive Loads (2.2A for Relay or (Solenoid) see below

** Limit to 500mA Maximum.

*** Limit to 300mA Maximum. Flywheel diode(s) should be connected across inductive Load(s)

WARNING: Fuel & Starter Outputs

Although the on board relays are quite capable of directly switching small solenoids, we would recommend that slave relays are always used as a matter of course unless both the Fuel & Starter Solenoid currents are known, and are within the specification of the RSM72. In line with other manufacturers, we quote the Fuel and Starter outputs as 16A (resistive) which relates to the contact ratings of the internal relays. However, as both Solenoids & Relays are inductive loads this 16A rating must **always** be de-rated to 14%, that is maximum continuous current of 2.2A to allow for a 'seven times' inrush, when the inductive load is energised.

WARNING: "OFF" - mode

In order to maximise flexibility, the mode control is effectively, independent of the '+Ve Start' input on Term.18. Thus, for 'Auto' operation Term.17 (Auto+ O/P) and Term.18 (Start + I/P) should always be connected via **VOLT-FREE** contacts, as a +Ve DC current applied to Term.18 (ie. via other circuitry) may allow the set to start &/or prevent it from stopping, when 'OFF' mode is selected.

As with all rotating machinery, an Emergency stop facility should be provided.

WARNING: Voltages dangerous to human life

Voltages **dangerous to human life** may be present at some of the terminal connections of this unit. Ensure that all AC and DC supplies isolated before attempting any connection / disconnection.

Basic Connections

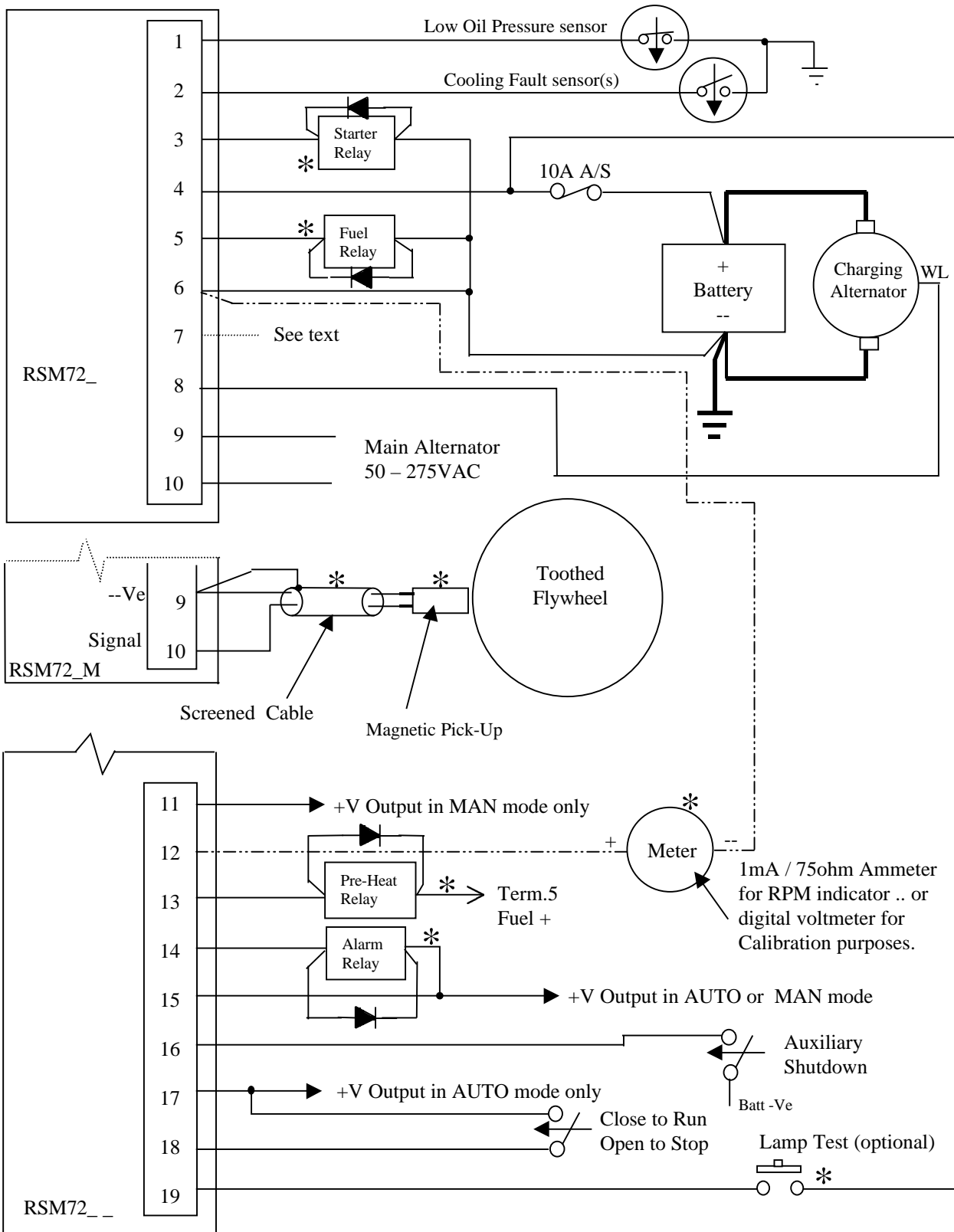

- NOTES :
- 1/ Items marked * are generally available 'ex-stock' from Capricorn Controls.
 - 2/ Starter Motor will not operate unless 'Low Oil Pressure' is sensed See text
 - 3/ Low Oil Pressure & Cooling Fault sensors are shown 'close to ground' on fault See text
 - 4/ Cooling Fault can be 'High Engine Temp' & / or 'Low Coolant Level'

Low Oil Pressure ‘Safety Circuit’

The starter relay cannot energise for each Crank Cycle unless a Low Oil Pressure input is sensed, to confirm that the engine is stationary. This is designed to prevent damage to the Starter Motor & Ring Gear in the event of the RSM72 not sensing that the engine has started (i.e. an open-circuit in the case of ‘Alternator Sensing’ or short-circuit in the case of Magnetic Pickup sensing).

If a ‘Low Oil Pressure’ switch cannot be fitted to the engine, the correct solution is to fit a Magnetic Pick-Up. However, if this is not possible the following circuit could be used --

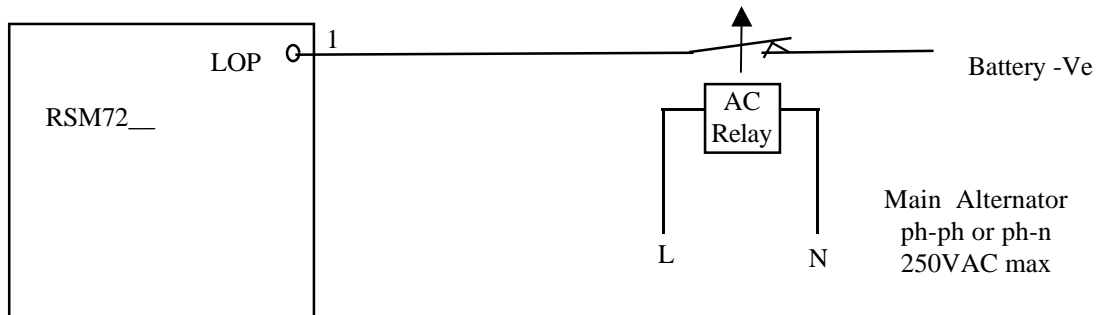

A suitable AC relay connected to the main alternator, as shown above, is de-energised when the engine is stationary. It's N/C contacts connect a Battery -Ve to the ‘Low Oil Pressure’ input so that the ‘Safety Circuit’ will enable the Starter Motor output. As the engine runs up to speed and the AC volts rise, the relay will energise and remove the Battery -Ve from the ‘Low Oil Pressure’ input. In the event of the AC Relay, de-energising while the engine is running normally, the engine will shutdown on the ‘Low Oil Pressure’ channel.

Note : If an RSM72__/LR (or /HLR) is used (where the ‘Low Oil Pressure’ input is reversed - to ‘open from ground’ on fault), the AC Relay contacts must be N/O.

WARNING:

If it is not possible to fit the above circuit (i.e. on a Pump-Set), a low oil pressure switch or a magnetic pick-up --- we can disable the 'safety-circuit' on request. However, we do not recommend this course of action as you risk damage to the engine, if for whatever reason, the starter should re-engage (into running engine).

A blank or named ‘over-stick’ label can be provided to rename the ‘Low Oil Pressure’ channel.

Operation of the RSM72 is not affected if a ‘High Engine Temperature’ switch is not available. The connection can be left ‘open-circuit’ or used to sense another fault condition and a blank or named ‘over-stick’ label can be provided to rename this channel.

However, in the case of an RSM72__/HR (or /HLR) where the HET input is ‘open from ground’ on fault, Term.2 must be wired to Batt -Ve if not used for another fault condition.

Noise Suppression Components

Both AC & DC inductive components (i.e. Relays, solenoids, etc) should be connected as shown --

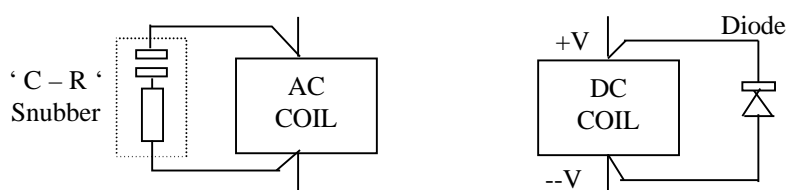

For further information or advice -
Please contact the sales desk

Wiring Instructions for specific Models

1/ The **RSM72A---** and **RSM72K---** are considered to be our standard models and in basic form are electrically identical. The 'A' version has a knob operated mode switch, while the 'K' version is key operated (single numbered key – removable in any position).

1/ **RSM72B---** & **RSM72C---** Mode control = Off - **Lamp Test** - Auto - Man

Terminal 19 (Lamp Test) is 'bi-directional'. That is, if an external DC voltage (12 or 24V) is applied to this terminal - all the LED's will light, irrespective of the mode control position. Alternatively, if the Lamp Test position is selected - all the LED's will light and a +Ve DC output (300mA Max) at term.19 can be used to 'globally' Lamp Test other modules &/or discrete circuits. For higher currents a suitable slave relay must be used. Note: 'Lamp Test' mode = 'Auto' operation

2/ **RSM72E---** External Mode Control only + Integral Lamp Test push button

RSM72F--- External Mode Control only

These models provide for Stop / Start push button control and / or an external Mode Control Switch.

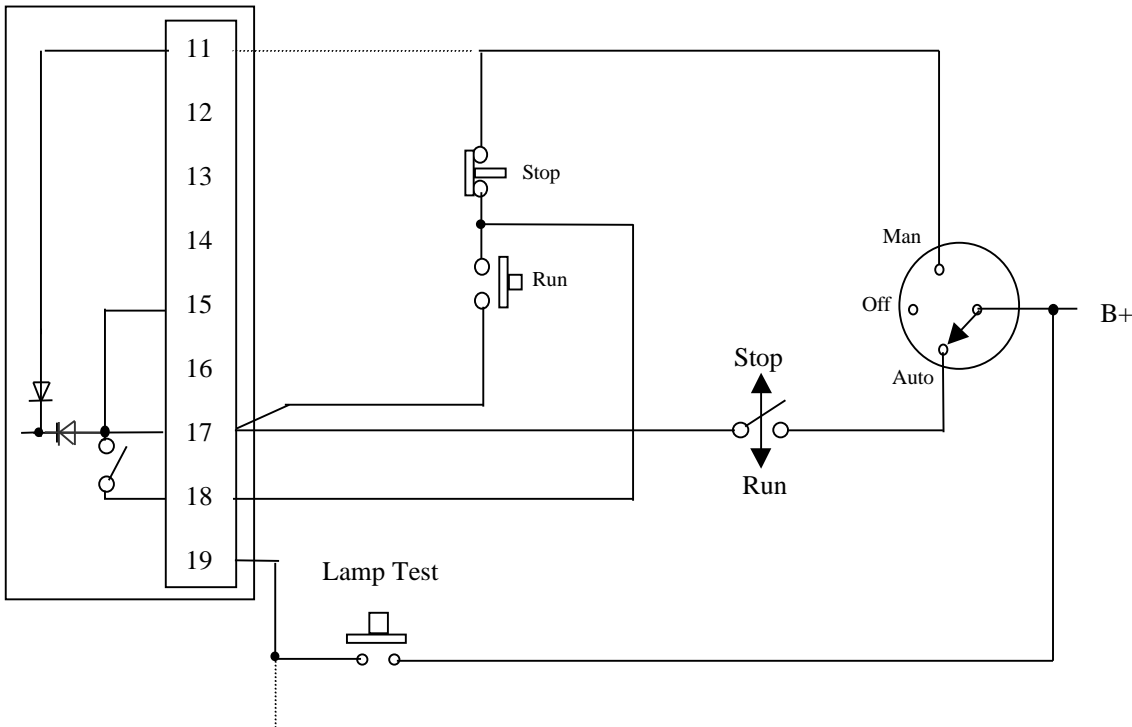

3/ **RSM72G---** Mode Control = Off - Auto - Man - **Test**

Typically used for 'Test on Load', when running in Manual Mode.

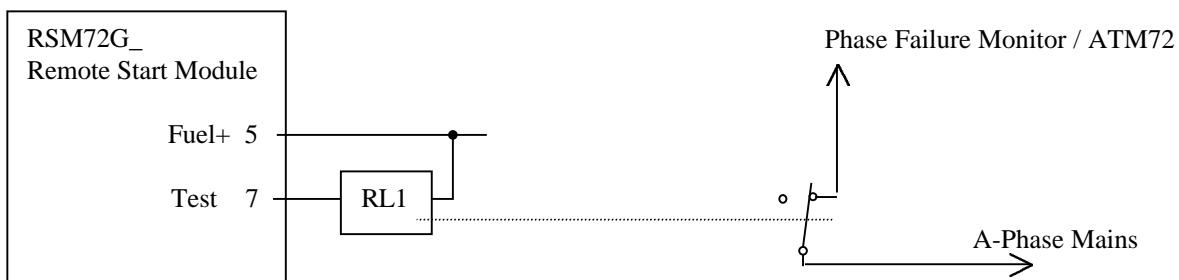

The (open collector transistor) **Test** output (term7 above) switches to battery -Ve (active-low) when the engine has achieved crank-cut speed with no fault shutdown present and 'Test' mode selected.

Relay RL1 (DC coil voltage to suit the Starter Batteries (i.e. 12 or 24VDC) **must be** connected to the Fuel Solenoid supply at term.5 as an internal fly-wheel diode is fitted. RL1 (n/c) contacts would normally be used to break the Mains AC sensing circuits to provide a simulated mains-failure / Test on load.

4/ **RSM72GW---** Mode Control = Off - Auto - Man - **Test**

This version requires term.7 for the 'W' Option (see overleaf). Therefore, the 'Active Low' **Test** output uses Term.13 in place of the 'Pre-Heat' output. Thus, **Pre-Heat, is not available on this build.**

Wiring Instructions for Specific Build 'Options'

1/ **RSM72--M--** Speed sensing via Magnetic Pick-Up (in place of main alternator frequency sensing).

Term. 9 (-Ve) and term.10 (signal) should be connected to the Magnetic Pick-Up terminals via a screened cable.

Always ensure that --

- (a) The screen is **ONLY** connected to term.9 and if wired via a terminal block, that the integrity of the screen is maintained.
- (b) If one of the Magnetic Pick-Up connections is connected to it's case, that this one is connected to term.9
- (c) The correct gap is set between the Magnetic Pick-Up and the Flywheel teeth.

2/ **RSM72--N--** Provision for external Stop/Start push buttons in **Man** mode

This version requires external connections in order to start the engine in Manual mode

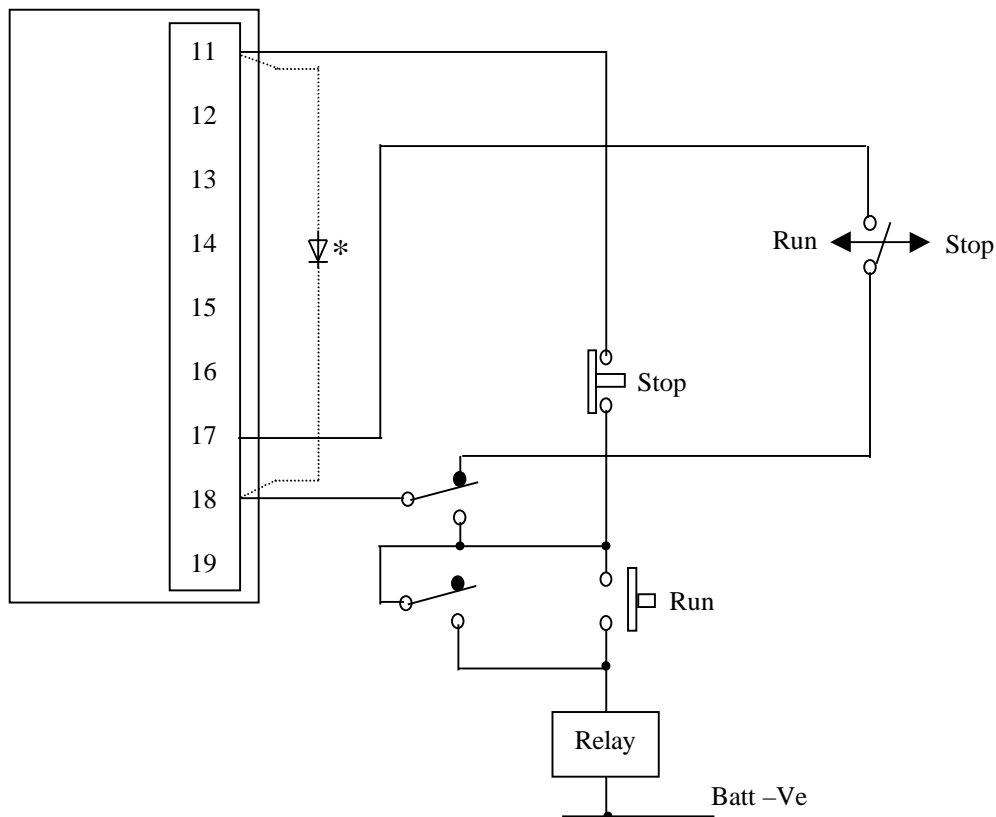

Note: Fit diode (*) as shown if 'Stop / Start' circuit not used and connect 'Run / Stop' volt-free contacts from term.17 to 18 as standard.

3/ **RSM72--R--** Seven, 'active-low' drivers allow external lamps &/or relays (150mA / 30VDC max each output) to be connected via an 8 way (top) connector. Typical applications include: remote indication (i.e. using an LPM72 Lamp Module) and volt-free contacts for 'Dial-Out' Alarm Systems.

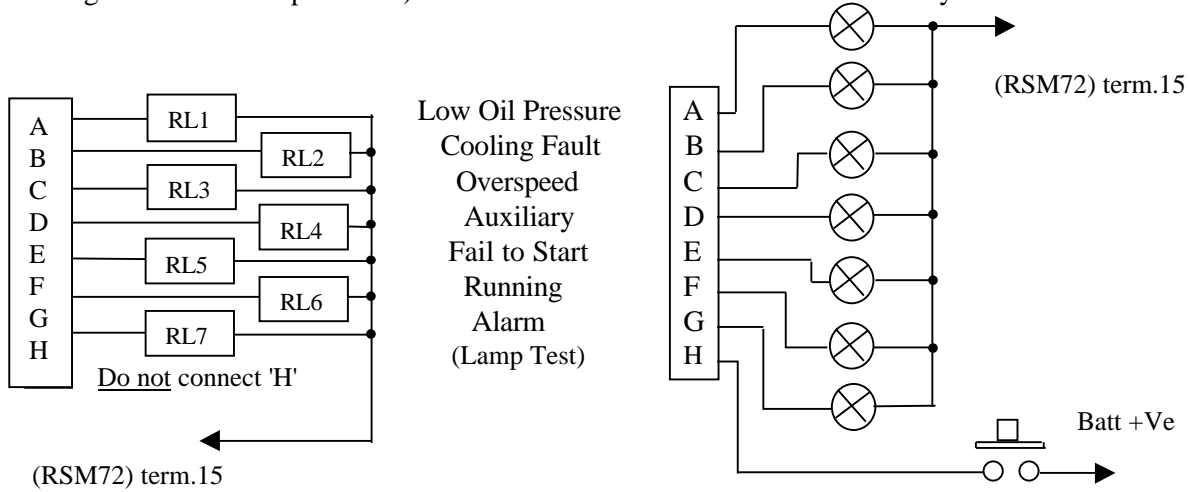

4/ **RSM72--T--** 'Active-Low' driver output (on term.7) at the end of the 'T0' hold-off timer period

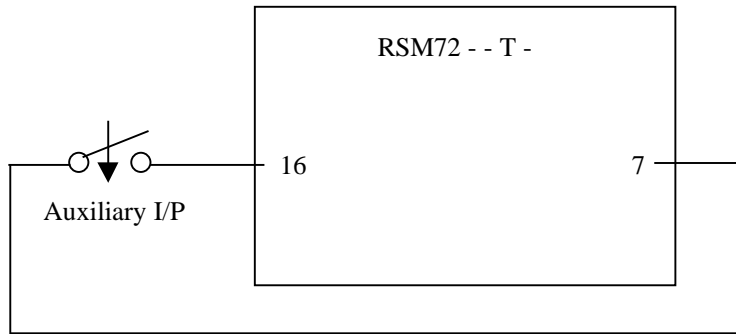

Connected as shown above, the 'Aux.' channel is subject to the 'T0' timer, and provided with 'First-up Interlock'. This 'T0' output is capable of sinking 300mA / 30VDC and could be used to drive an external relay (connected to term.15).

5/ **RSM72--W--** Active-Low 'Enable' driver output (on term.7) at 'Crank-Cut' (engine running). This is normally used with EXM72-W Expansion Modules. In the event of a fault shutdown, this driver output is disabled. This 'Enable' output is capable of sinking 300mA / 30VDC and could be used to drive an external relay or timer (connected to the +Ve fuel solenoid output on term.5) i.e. to energise a Contactor coil in an RSM72 'stand-alone' system.

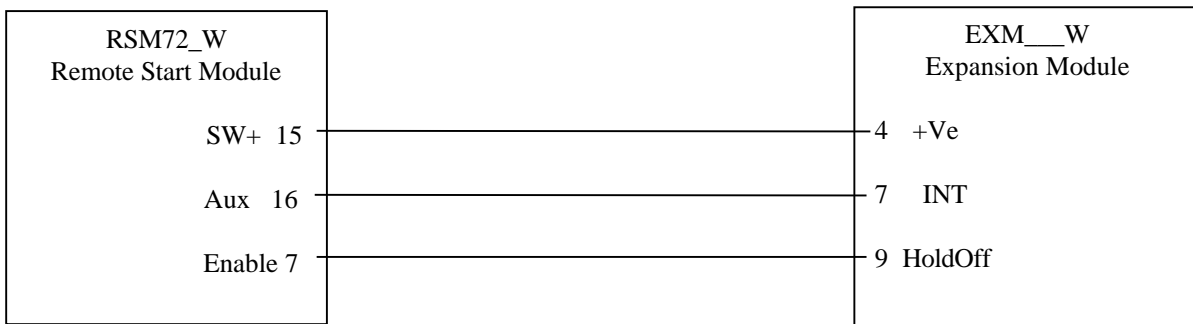

Please refer to the EXM72 'Data & Application Note' for further information

FAULT FINDING ----- RSM72 BASED SYSTEMS

Always check the 'obvious' first ----

- ◆ System correctly wired
- ◆ Correct RSM72 type fitted for the specific application
- ◆ RSM72 suitably calibrated
- ◆ All connections use suitably rated cables to comply with all appropriate regulations.
- ◆ All terminal screw connections tight.
- ◆ Battery(s) charged, in good condition, clean & tight connections and of the correct voltage
- ◆ The Module MUST be fitted in a control panel with adequate protection from extremes of Temperature, Humidity & Vibration

WARNING - Incorrect wiring could damage the module i.e. -

- 1/ Loss of battery negative (term.6)
- 2/ Connecting any 'Active low' outputs (i.e. Pre-Heat, Alarm, etc.) directly to a positive supply.
- 3/ connecting any positive DC outputs (i.e. Starter, Fuel, Exc.+, etc.) directly to a negative supply.
- 4/ connecting any DC terminals to an AC supply.

- **Unit Dead - set will not start :**

Check for battery supply on term.4(B+) and term.6(B-) of the RSM72 using a DC voltmeter or by shorting term.4 to term.19 (lamp test) and observing if the Led's light.

- **Engine starts in MANual mode but not in AUTOMATIC :**

For all models (excluding the RSM72F version) - the module only operates whilst terminals 17 and 18 are connected via external 'volt-free' contacts (ie. remote switch) when in 'Auto' mode.

- **Engine starts &/or not stopping when 'OFF' mode selected :**

There is a positive current path direct to Term.18 when the mode control is in the 'OFF' position (Term.11 & 17 isolated from Batt+Ve). This current path could be direct from the battery or via a de-energised relay or solenoid coil.

- **False tripping of Overspeed shutdown :**

- (a) *Module requires calibration (see below)*
- (b) *Open-circuit probe (magnetic pick-up version ONLY). Always use a screened cable where the screen is connected to Batt-Ve at the controller end only.*
- (c) *Engine 'overspeeding'.*
- (d) *External relays and Contactor coils may require noise suppression components (see page 5).*

- **Fuel operates but no Starter :**

- (a) *Preheat timer set near maximum (50secs), wait for this time to elapse.*
- (b) *If 'Low Oil Pressure' is not sensed, a safety circuit locks out the starter (see text).*

- **Engine starts correctly and then shuts-down on 'Fail to Start' :**

- (a) *Short-circuit probe or probe too far from flywheel teeth (magnetic pick-up version ONLY).*
- (c) *AC sensing version - short-circuit, open-circuit or with a voltage <50VAC or frequency incompatible with the RSM72 type fitted.*

- **No Pre-Heat output :** *Pre-Heat timer (0 - 50 sec) set near minimum, adjust to suit application.*

- **Low oil pressure shutdown :** *Faulty pressure switch, incorrect type or trip setting*

- **Cooling Fault (High engine temp.) shutdown :** (b) *Faulty temperature switch, incorrect type or trip setting*

(c) *Incorrect RSM72 type for use with Temperature switch fitted*

- **Charging Alternator fails to excite :**

- (a) *incorrect type of RSM72 fitted*
- (b) *rear mounted 82R resistor damaged, missing or too high a value (may require 47R on certain 12VDC Alternators).*
- (c) *charge fail (term.8) not connected to WL. connection on the charging alternator*

- **Overspeed and / or Nominal-Speed Calibration :**

- (a) *Connect a digital (or other D.C voltmeter) to term.12 (meter +) and battery negative*
- (b) *Run engine at or close to normal speed, measure & note the actual frequency (or speed using a tacho)*
- (c) *Calculate: Meter output (at required Overspeed) = OS / Nominal x 2.50 (i.e. [57Hz / 50Hz] x 2.50V = 2.85V)*
- (d) *Set 'Overspeed Trip' pot fully **anti-clockwise**, adjust the 'Speed Cal' pot until the meter reads 2.85V*
- (e) *Slowly, wind the 'Overspeed Trip' pot **clockwise** until the unit (just) shutsdown on Overspeed.*
- (f) *Wind 'Cal' potentiometer 3 turns **anti-clockwise**. Repeat (b).*
- (g) *Adjust Cal pot for meter output = Actual / Nominal x 2.50V (i.e. [52Hz / 50Hz] x 2.50V = 2.60V)*

SPECIFICATION

Supply

12 / 24V Single range supply, operating from 4V to 40VDC (absolute Minimum / Maximum)

Speed Sensing

Magnetic Pickup 600 Hz to 6 kHz at rated speed. (5V to 100Vac pk - pk)

Alternator 50 Hz to 400 Hz at rated speed. (30V to 300V Rms. absolute Maximum)

Adjustable Functions

Pre-Heat Timer 0 - 50 sec (set at minimum, unless requested otherwise)

Pulse Timer 5 - 15 sec (set at 10sec, unless requested otherwise)

Hold-Off Timer 5 - 25 sec (set at 25sec, unless requested otherwise)

Speed Calibration --- Set 'Cal' potentiometer for meter output = 2.50Vat Nominal Speed

Crank Cut Level 15 - 60% of Rated Speed (factory set at 40% unless requested otherwise)

Overspeed Trip Level 102 - 125% of Rated Speed (set at 117% unless requested otherwise)

General

Ambient temperature -10⁰C to +55⁰C Operating, -25⁰C to +70⁰C Storage

Construction

Through panel fitting, 72mm sq. DIN standard case. Reverse screen-printed "LEXAN" front panel.

Printed Circuit Boards are varnished as standard.

Dimensions

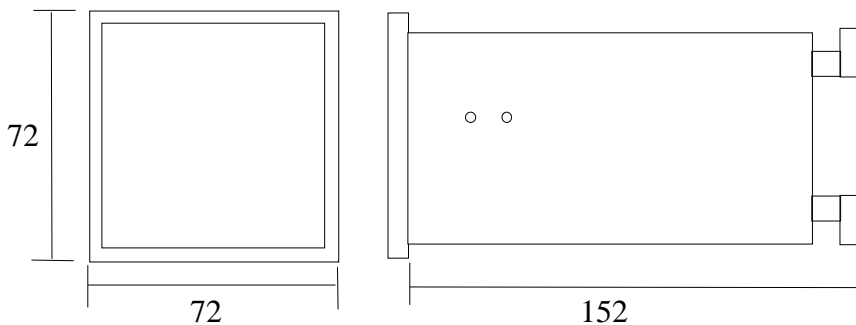

Notes:

1/ Not to Scale

2/ All dimensions in mm

3/ Panel cut-out
68 x 68 mm

MOUNTING

The module must be fitted into a suitable control panel that provides adequate protection from the extremes of Temperature, Humidity & Vibration. If this control panel is set-mounted then suitable 'Anti-Vibration' mounts MUST be used

Note: If specific information or a replacement unit is required, please ensure that the 'Serial Number' of the original unit is quoted.

Industrial Diesel Products Inc.

7850 Tranmere Dr. Mississauga, Ontario, Canada. L5S 1L9

Tel: 905-362-0423 Toll Free 1-800-668-4835

Fax: 905-362-5015 Toll Free 1-800-668-7450

E-mail: sales@dieselproducts.com Web: www.dieselproducts.com